



BOILER AUTOMATIC BOTTOM BLOWDOWN SYSTEMS

DBV-10



DBV-10 BOILER AUTOMATIC BOTTOM BLOWDOWN SYSTEMS

The formation of hard accumulation in boilers (stone and mud) is caused by some impurities and corrosion products contained in water. Examples of water impurities are; dissolved calcium, magnesium chloride, sulfate and silicon elements; Examples of corrosion products include iron and copper. The water impurities in the boiler consist of condensate leaks and boiler feed water (make-up); Corrosion products, as a result of corrosion, also comes from the condensate and feed water.

Deposits cause a waste of fuel in the boiler, a slight decrease in productivity, and more importantly, overheating occurs metal annealing and pipe explosion. The boiler zone where the accumulation causes the biggest problem is the evaporator pipes around the burners in the combustion chamber. The system that is used to prevent the problems caused by these hard accumulation compounds and to expurge hard materials from the boiler is called Boiler Automatic Bottom Blowdown Systems

ACCUMULATION (STONE) TYPES

Calcium carbonate (the most common type of stone), calcium sulfate, silica, phosphate stones, magnesium and magnesium stones, aluminum, iron oxides (usually in the boiler and condensate line is the product of corrosion).

ACCUMULATION EFFECTS

Reduced thermal conductivity: stones are poor heat conductors and act as insulators as indicated by the various conductivity values. The resulting furring layer causes the reduction of steam generation. In addition, the resulting furring layer increases the fuel consumption and increases the unit cost of steam generation.

Temperature build-up in the metal wall: As a stone-coated wall prevents heat transfer, the wall temperature rises. This is called overheating and the metal may lose some of its mechanical properties (elasticity, etc.). These cause local shape disturbances and cause pipe explosion.

Blowdown Systems Components

-BLOWDOWN VALVE V-3F-

Body and Cover : AISI 304 Stainless Steel(Opt. AISI 316)

Working Temperature : -50 / +210°C

Pressure Class : PN40

- TIME CONTROLLER
- ACTUATOR TYPE: SINGLE EFFECTIVE PNEUMATIC ACTUATOR SPRING
- SOLENOID VALVE
- LIMIT SWITCH

Note : The settings are not changed when the 220 V 50 Hz power is cut off in the timer.

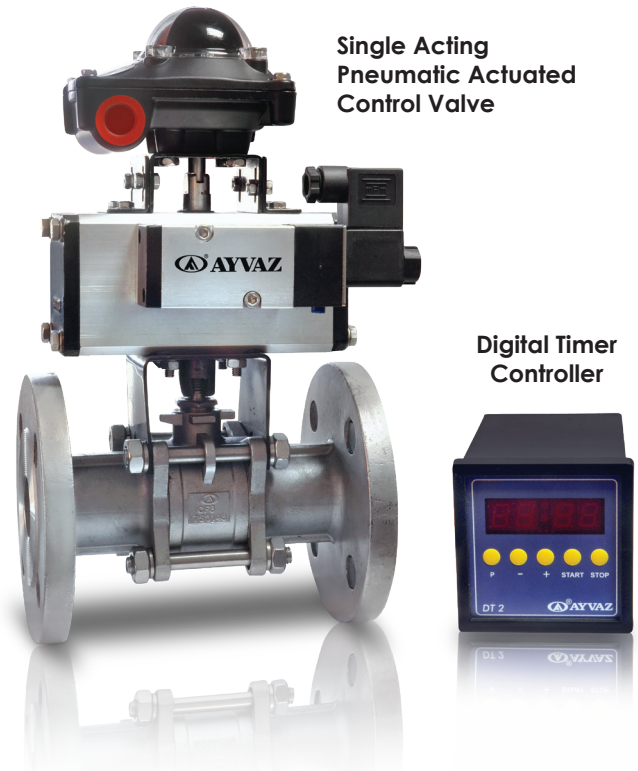

Single Acting
Pneumatic Actuated
Control Valve

Digital Timer
Controller

ADVANTAGES OF AUTOMATIC BOTTOM BLOWDOWN SYSTEM

- Provides fuel saving by discarding solid elements.
- Adjustable application time and time of blowdown.
- The boiler production efficiency is not reduced, because of less blowdown than required.
- It does not cause energy loss due to unnecessary blowdown.
- Blowdown time is set, so that there will not be unnecessary or low blowdown.

DBV-10 BOILER AUTOMATIC BOTTOM BLOWDOWN SYSTEMS

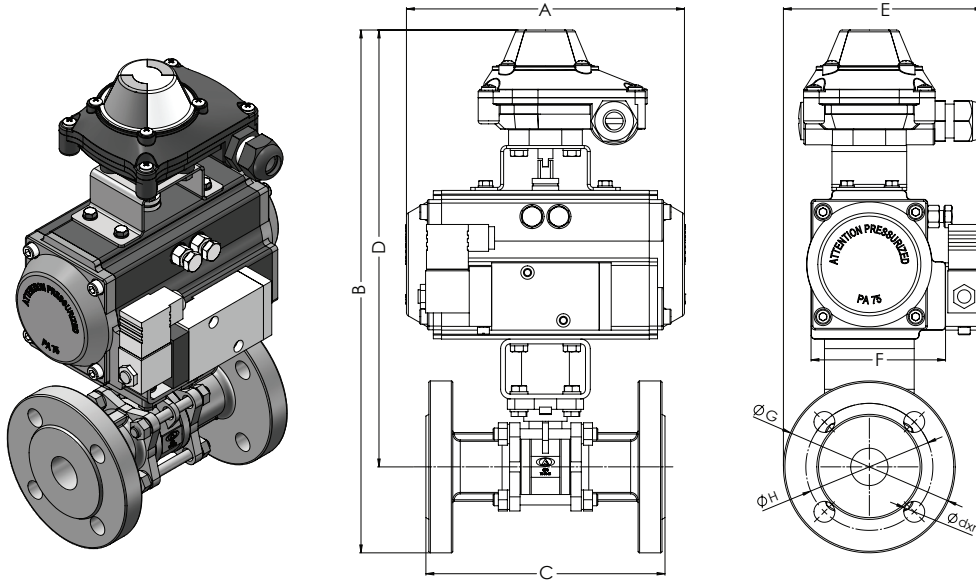

Dia.	A	B	C	D	E	F	ØG	ØH	dxn
DN25	186	350	160	292	134	90	115	85	Ø14x4
DN32	205	388	180	318	152	96	140	100	Ø18x4
DN40	253	410	200	335	158	102	150	110	Ø18x4
DN50	253	425	230	343	166	102	165	125	Ø18x4
DN65	267	431	290	339	185	115	185	145	Ø18x8

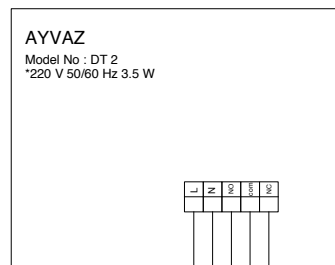
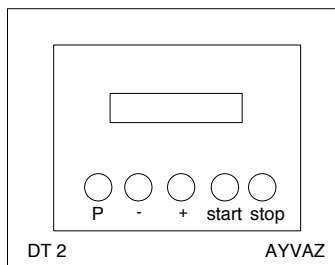

Electric Connection Scheme

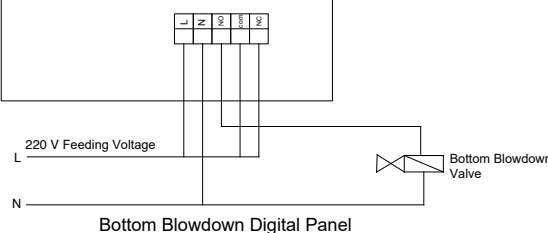

DFC; F5A A-B; 6CHCA 6CK 8CK B GMDA

i 'Hc 'gYhHAY 'hja Y 'dYfjC X '%Ubx ' &zd fYggD' _Ym%hja Y 'UZHfUdd'mb['dck Yfrc 'hAY 'XYj jW''
 i 'HAY 'gYWc bX 'dYfjC X 'cZ'hja Y 'cb 'hAY 'fj[\hgXY 'cZ'hAY 'X]gd' Umk j' 'ZUgY 'Zc f'hAY 'gY Wc bX 'dYfjC X''
 i 'GYhHAY ' &bX 'hja Y 'dYfjC X 'k j'h 'hAY 'Z' UbX '! _YngZc f'U' a UI]a i a 'cZ%' gY Wc bX gUX ↑ gfa Ybh'
 i 'DfYggD'hk jW' hc 'gYc fY 'hAY 'gY Wc bX g dYfjC X''
 i 'HAY 'X]gd' Umk j' 'gYc k 'hAY '\ci f'UbX 'a]bi hY 'dYfjC X'Zk \jW' a YUbg%' Hja Y 'dYfjC X'' hAY '\ci f'Z' bWjcb' fYa U]bg gY UXMUbX '
 hAY 'a]bi hY 'Z' bWjcb' ZUgYg'
 i 'HAY 'hja Y 'Z' bWjcb' cZ'hAY 'hja Y 'dYfjC X']ggYhk j'h 'hAY 'Z' UbX '! _YngZc f'U' a UI]a i a 'cZ' - 'a]bi hY g'UbX 'dYfjC b['hAY 'D' _Ymhc '
 gYhHAY 'a]bi hY g'Z' bWjcb''
 i '5ZHf'h]g'cdYfUhc bZ'hAY 'hja Y 'Z' bWjcb' cZ'hAY 'g'hja Y 'dYfjC X 'k j' 'gUfh'hc 'ZUgY''
 i 'HAY 'hja Y 'Z' bWjcb' cZ'hAY 'hja Y 'dYfjC X']ggYhk j'h 'hAY 'Z' UbX '! _YngZc f'U' a UI]a i a 'cZ&' '\ci f'g'UbX 'dYfjC b['hAY 'D' Vi h'c b'hc '
 gYc fY 'hAY 'Wc W_ 'Z' bWjcb''
 i '5ZHf'h]g'cdYfUhc bZ'hAY 'gWYyb'k j' 'VY 'gY UXMUbX 'hAY 'XYj jW' 'k j' 'VY 'd'fc[fUa a YX''

INSTALLATION

