

SIGHT GLASS

GENERAL FEATURES

Flow Indicator; It is an element used to monitor the flow of closed pipe line circuits from different directions. The flow indicators are connected before and after the steam traps to monitor the steam leak. They are used to provide visual control of the fluid in industry. Glasses used in sight glasses are specific, also known as tempered sodalime glass. These glasses do not break apart at breakage. Optionally, the working temperature can be increased to 300 ° C by changing the borasilicate glass and gasket.

Product Features:

Body:	GG-25 Iron Casting
Glass:	Tempered Sodalime Glass (max. 150 °C)*
Gasket:	PTFE
Connection:	Threaded/Flanged
Max. Working Pressure:	16 bar
Working Temperature:	-30 / +150°C

Application Areas

Cold water, Hot water, Steam, LPG, LNG, Asphalt, Pressure Air, Fuel Oil, Liquid Ceramic

SIGHT GLASS

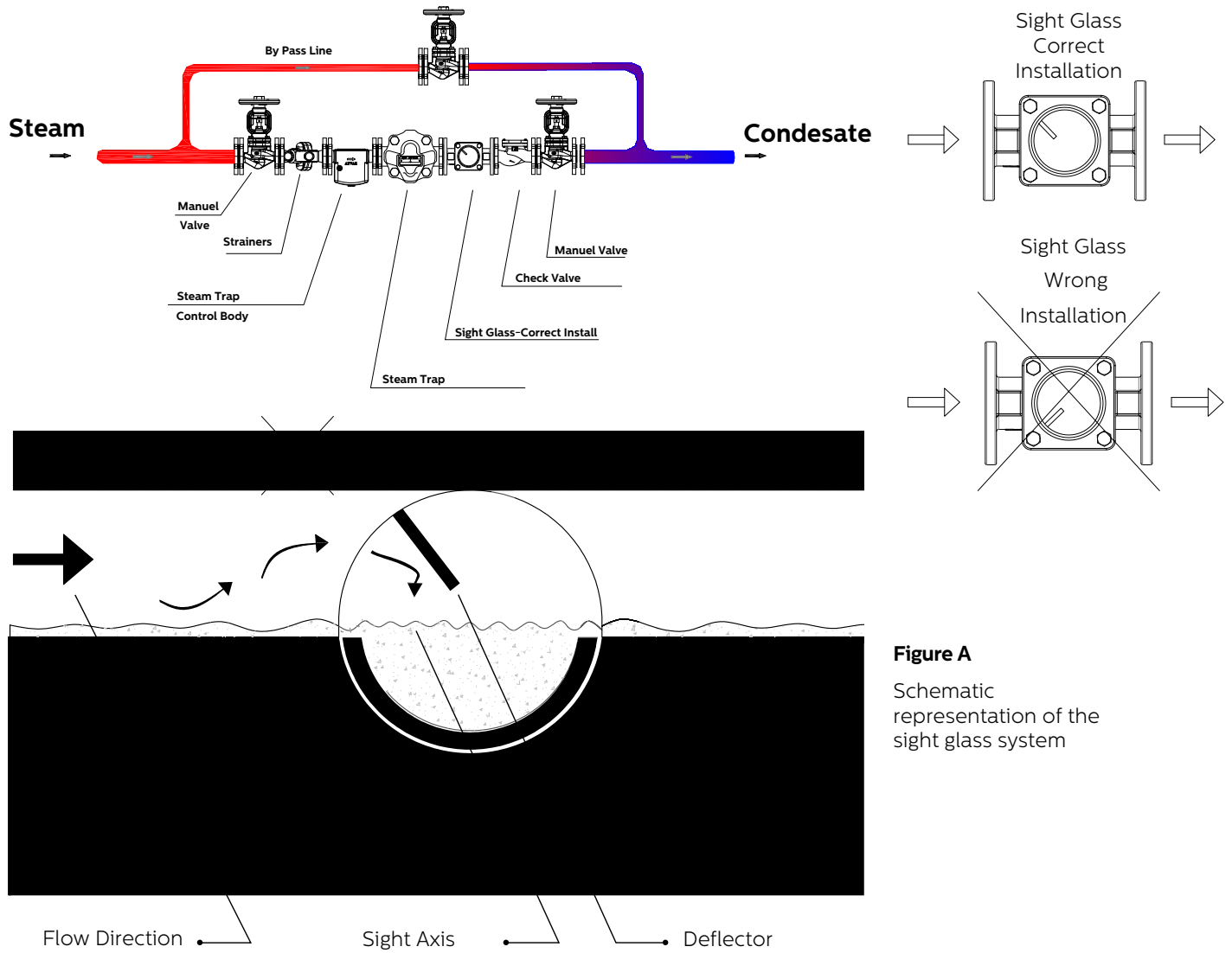

Figure A
Schematic representation of the sight glass system



Figure B/Normal Operation
The deflector below sight axis, there is no steam leak, the steam trap is operating normally.



Figure C/Condensate Water Accumulate
If the flow indicator is completely covered by water, it must be understood that the sight glass installed very close to the system and there is condensate accumulation in the device with heat transfer. As the result that the steam trap capacity is insufficient.



Figure D/Steam Leak
The passing steam has significantly suppressed the water surface. Steam filled the area between the deflector and the water surface. That means, the steam trap is leaking steam.

SIGHT GLASS

Determination of the steamtrap function with the help of a sight glass placed behind the trap:

Waste steam and clean steam are not different from each other. The steam volume depends on the operating pressure and the amount of condensate created. There could be minimum level waste steam around the sight glass, that reaches the turbulent high flow rate, the values that could be unhealthy in the small sight glass. Only the opening and closing operation can be observed in the thermodynamic steam trap. In the meantime, clean steam leak can not be detected.

Determination of the steamtrap function with the help of a sight glass or control unit placed in front of the steamtrap:

A sight glass placed in front of the steam trap in the physically correct position allows practically complete control. There could not any mistake here because of flash steam. However, it requires the usage of high-quality, pressure-resistant and high cost body material and glass instead of a sight glass placed the steam trap.

The sight glass can be used for visual steam trap control. If the sight glasses are installed in the front of the steam trap, optimum monitoring of the steam trap is achieved. Thus, not only the smallest clean steam leaks, but even the smallest condensate formation can be seen. Not only important for the water heating in condensate line. Also second sight glass is recommended to install behind the exchanger's condensate outlet, if it is necessary to check the heating element is free from condensate.

FLANGED CONNECTION

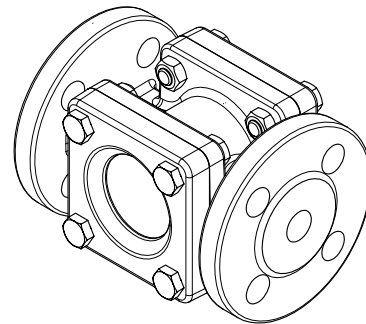
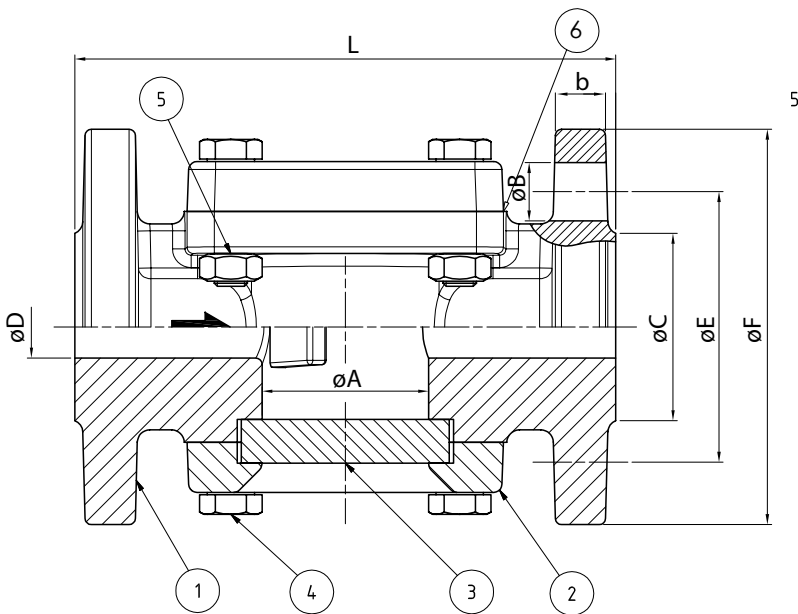

- 1-Body: GG - 25 Iron Casting
- 2-Cover: GG - 25 Iron Casting
- 3-Glass: Tempered Sodaime Glass
- 4-Bolt: Stainless Steel
- 5-Nut: Stainless Steel
- 6-Gasket: PTFE

SIGHT GLASS

Threaded Connection

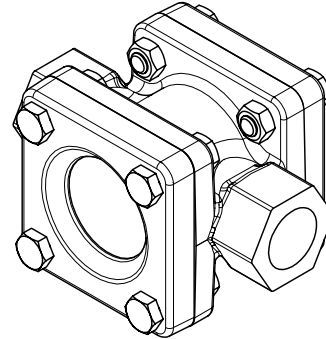
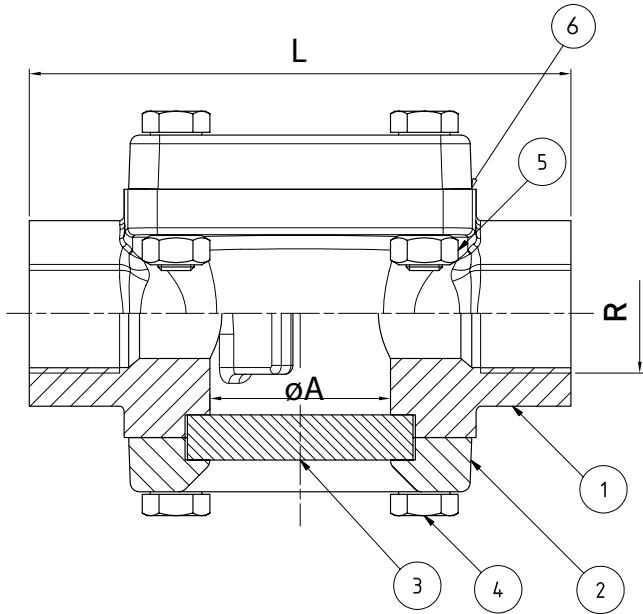

- 1-Body: GG - 25 Iron Casting
- 2-Cover: GG - 25 Iron Casting
- 3-Glass: Tempered Sodaime Glass
- 4-Bolt: Stainless Steel
- 5-Nut: Stainless Steel
- 6-Gasket: PTFE

DIAMETER	Flanged										DIAMETER	Threaded			
	A	C	D	E	F	L	b	Num. of Holes	Hole Dia.	Weight (kg)		A	R	L	Weight (kg)
DN15	40	46	15	65	95	130	14	4	14	3,2	1/2"	40	15	100	2,1
DN20	40	56	20	75	105	150	16	4	14	3,7	3/4"	40	20	120	2,1
DN25	48	65	25	85	115	160	16	4	14	4,2	1"	50	25	135	2,2
DN32	67	76	32	100	140	180	16	4	18	6,4	1 1/4"	70	32	158	3,5
DN40	68	84	40	110	150	200	16	4	18	7,3	1 1/2"	68	40	185	3,9
DN50	85	99	50	125	165	230	18	4	18	10,7	2"	85	50	219	6,2
DN65	100	122	65	145	185	290	18	4	18	15					
DN80	100	138	80	160	200	310	20	8	18	19					
DN100	125	158	100	180	220	350	20	8	18	33					



HEAD OFFICE - FACTORY

Atatürk Sanayi Bölgesi Hadımköy Mahallesi Mustafa İnan Caddesi No: 44 Arnavutköy - İSTANBUL
 Tel: +90 212 771 01 45 (pbx) | Fax: +90 212 771 47 27
 info@ayvaz.com | www.ayvaz.com

Caserta/Italy Tel: +39 0823 187 3988 rmolaro@ayvaz.com	Moscow/Russia Tel: +74959951728 ayvazrus@ayvaz.com	Viernheim/Germany Tel: +49 62046014399 germany@ayvaz.com	Kiev/Ukraine Tel: +380 44 390 57 57 info@ayvaz.com.ua	Warsaw/Poland Tel: +48-32-783-295-1 tricorr@tricorr.eu
Dubai/U.A.E Tel: +971 563550822 +971 501306871 mideast@ayvaz.com	Cixi City/China Tel: +86 574-58973851 info@ayvazchina.com	Kazakhstan Tel: +7 (701) 066 066 1 +90 (533) 760 34 66 celyas@ayvaz.com	Isperih/Bulgaria Tel: +359 8431 27 32 office@ayvaz-n.eu	Belgrad/Serbia Tel: +381 61 658 70 52 yakbiyik@ayvaz.com